

MC Key

1. D

2. C

3. E

4. B

~~5. B~~ (Cancelled)

6. A

7. D

8. D

9. C

10. A

11. B

12. E

13. D

14. B

15. D

16. A

17. A

18. C

19. E

20. D

Long Questions

1.

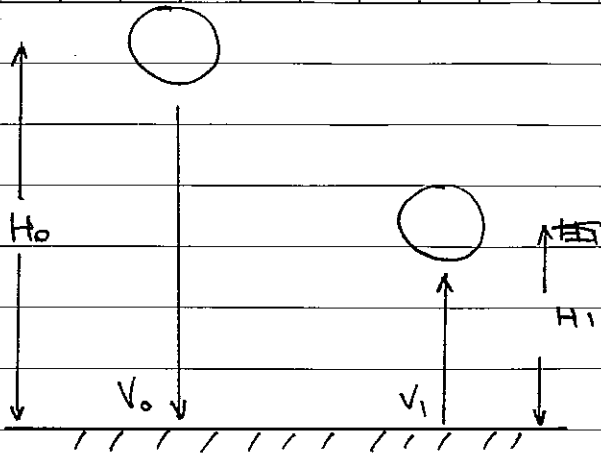

$$s = \frac{1}{2} g t^2$$

$$v_0 = g \sqrt{\frac{2H_0}{g}}$$

$$v_1 = g \sqrt{\frac{2H_1}{g}}$$

$$(a) \quad C_R = \frac{g \sqrt{\frac{2H_1}{g}}}{g \sqrt{\frac{2H_0}{g}}} = \sqrt{\frac{H_1}{H_0}}$$

$$(b) \quad H_{\text{total}} = H_0 + \underbrace{2H_1 + 2H_2 + \dots}_{\text{include round trip distance}}$$

$$H_1 = C_R^2 H_0$$

$$H_2 = C_R^2 H_1 = C_R^2 C_R^2 H_0 = C_R^4 H_0$$

$$H_3 = C_R^6 H_0$$

$$H_{\text{total}} = H_0 + 2C_R^2 H_0 + 2C_R^4 H_0 + 2C_R^6 H_0 + \dots$$

$$= H_0 [1 + 2C_R^2 + 2C_R^4 + 2C_R^6 + \dots]$$

$$= H_0 [2(1 + C_R^2 + C_R^4 + C_R^6 + \dots) - 1]$$

$$= H_0 \left[2 \left(\frac{1}{1 - C_R^2} \right) - 1 \right]$$

$$(c) \quad t_{\text{total}} = t_0 + t_1 + t_2 + \dots$$

$$t_0 = \left(\frac{2H_0}{g} \right)^{\frac{1}{2}}$$

$$\begin{aligned} t_1 &= 2 \left(\frac{2H_1}{g} \right)^{\frac{1}{2}} \\ &= 2 \left(\frac{H_1}{H_0} \right)^{\frac{1}{2}} \left(\frac{2H_0}{g} \right)^{\frac{1}{2}} \\ &= 2 C_R \left(\frac{2H_0}{g} \right)^{\frac{1}{2}} \end{aligned}$$

$$\begin{aligned} t_2 &= 2 \left(\frac{2H_2}{g} \right)^{\frac{1}{2}} \\ &= 2 \left(\frac{H_2}{H_1} \right)^{\frac{1}{2}} \left(\frac{H_1}{H_0} \right)^{\frac{1}{2}} \left(\frac{2H_0}{g} \right)^{\frac{1}{2}} \\ &= 2 C_R^2 \left(\frac{2H_0}{g} \right)^{\frac{1}{2}} \end{aligned}$$

where t_1, t_2, \dots include round trip time

$$\begin{aligned} t_{\text{total}} &= \left(\frac{2H_0}{g} \right)^{\frac{1}{2}} \left[2(1 + C_R + C_R^2 + C_R^3 + \dots) - 1 \right] \\ &= \left(\frac{2H_0}{g} \right)^{\frac{1}{2}} \left[2 \left(\frac{1}{1 - C_R} \right) - 1 \right] \end{aligned}$$

2.

(a) x-component: $T_2 \sin \theta_2 - T_1 \sin \theta_1 = 0$

$$\Rightarrow T_2 = T_1 \frac{\sin \theta_1}{\sin \theta_2} \quad \text{--- (1)}$$

y-component: $T_1 \cos \theta_1 + T_2 \cos \theta_2 - 3mg = 0$ --- (2)

About the position of the lead:

$$-x T_1 \cos \theta_1 - \left(\frac{L}{2} - x \right) mg + (L-x) T_2 \cos \theta_2 = 0 \quad \text{--- (3)}$$

(1) and (2)

$$\Rightarrow T_1 \cos \theta_1 + T_1 \frac{\sin \theta_1}{\sin \theta_2} \cos \theta_2 - 3mg = 0$$

$$T_1 \left(\cos \theta_1 + \frac{\sin \theta_1}{\sin \theta_2} \cos \theta_2 \right) = 3mg$$

$$T_1 \left(\frac{\sin \theta_2 \cos \theta_1 + \sin \theta_1 \cos \theta_2}{\sin \theta_2} \right) = 3mg$$

$$T_1 \frac{\sin(\theta_1 + \theta_2)}{\sin \theta_2} = 3mg$$

$$T_1 = \frac{3mg \sin \theta_2}{\sin(\theta_1 + \theta_2)}$$

$$T_2 = T_1 \frac{\sin \theta_1}{\sin \theta_2}$$

$$= \frac{3mg \sin \theta_2}{\sin(\theta_1 + \theta_2)} \cdot \frac{\sin \theta_1}{\sin \theta_2}$$

$$= \frac{3mg \sin \theta_1}{\sin(\theta_1 + \theta_2)}$$

$$(b) \quad (3) \Rightarrow (-T_1 \cos \theta_1 + Mg - T_2 \cos \theta_2) x = \frac{L}{2} Mg - T_2 L \cos \theta_2$$

$$\left[-3Mg \frac{\sin \theta_2}{\sin(\theta_1 + \theta_2)} \cos \theta_1 + Mg - 3Mg \frac{\sin \theta_1}{\sin(\theta_1 + \theta_2)} \cos \theta_2 \right] x$$

$$= \frac{L}{2} Mg - 3Mg \frac{\sin \theta_1}{\sin(\theta_1 + \theta_2)} L \cos \theta_2$$

$$\left[\frac{-3Mg \sin \theta_2 \cos \theta_1 + Mg \sin(\theta_1 + \theta_2) - 3Mg \sin \theta_1 \cos \theta_2}{\sin(\theta_1 + \theta_2)} \right] x$$

$$= \frac{\frac{L}{2} Mg \sin(\theta_1 + \theta_2) - 3Mg \sin \theta_1 L \cos \theta_2}{\sin(\theta_1 + \theta_2)}$$

$$\left[-3 \sin \theta_2 \cos \theta_1 + \sin(\theta_1 + \theta_2) - 3 \sin \theta_1 \cos \theta_2 \right] x$$

$$= \frac{L}{2} \sin(\theta_1 + \theta_2) - 3L \sin \theta_1 \cos \theta_2$$

$$\left[\sin(\theta_1 + \theta_2) - 3 \sin(\theta_1 + \theta_2) \right] x = \frac{L}{2} \sin(\theta_1 + \theta_2) - 3L \sin \theta_1 \cos \theta_2$$

$$x = \frac{\frac{L}{2} \sin(\theta_1 + \theta_2) - 3L \sin \theta_1 \cos \theta_2}{-2 \sin(\theta_1 + \theta_2)}$$

$$= \frac{3L}{2} \frac{\sin \theta_1 \cos \theta_2}{\sin(\theta_1 + \theta_2)} - \frac{L}{4}$$

$$(c) \quad \theta_1 + \theta_2 = 90^\circ$$

$$\Rightarrow x = \frac{3L}{2} \sin \theta_1 \cos \theta_2 - \frac{L}{4}$$

$$= \frac{3L}{2} \left[\frac{1}{2} (\sin(\theta_1 - \theta_2) + \sin(\theta_1 + \theta_2)) \right] - \frac{L}{4}$$

$$= \frac{3L}{4} \sin(\theta_1 - \theta_2) + \frac{3L}{4} - \frac{L}{4}$$

$$= \frac{3L}{4} \sin(\theta_1 - \theta_2) + \frac{L}{2}$$

$$(c) \quad x = \frac{L}{8}$$

$$\Rightarrow \frac{L}{8} = \frac{3L}{4} \sin(\theta_1 - \theta_2) + \frac{L}{2}$$

$$\sin(\theta_1 - \theta_2) = -\frac{1}{2}$$

$$\begin{cases} \theta_1 - \theta_2 = -30^\circ \\ \theta_1 + \theta_2 = 90^\circ \end{cases}$$

$$\Rightarrow \begin{aligned} \theta_1 &= 30^\circ \\ \theta_2 &= 60^\circ \end{aligned}$$

3.

$$(a) \quad KE = \frac{56}{5} MR^2 \left(\frac{\Delta\theta}{\Delta t} \right)^2$$

For a displacement θ ,
 $h = 4R(1 - \cos\theta)$

$$PE = mgh = 4MgR(1 - \cos\theta)$$

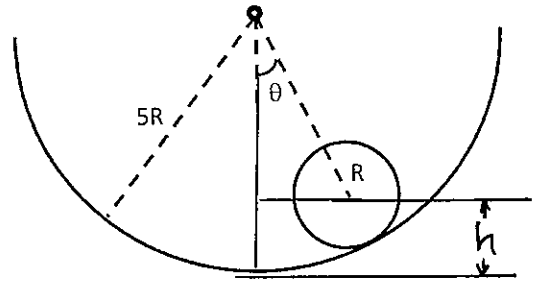

(b) For small angle, $(1 - \cos\theta) \approx \frac{\theta^2}{2}$

$$\Rightarrow PE \approx 4MgR\theta^2$$

$$\begin{aligned} \text{Total Energy} = \text{Constant} = E &= \frac{56}{5} MR^2 \left(\frac{\Delta\theta}{\Delta t} \right)^2 + 4MgR\theta^2 \\ &= \frac{1}{2} \left(\frac{112}{5} MR^2 \right) \left(\frac{\Delta\theta}{\Delta t} \right)^2 + \frac{1}{2} (4MgR) \theta^2 \end{aligned}$$

$$(c) \quad M_{\text{eff}} = \frac{112}{5} MR^2$$

$$k_{\text{eff}} = 4MgR$$

$$\begin{aligned} \omega &= \sqrt{\frac{k_{\text{eff}}}{M_{\text{eff}}}} = \sqrt{\frac{4MgR}{\frac{112}{5} MR^2}} \\ &= \sqrt{\frac{5g}{28R}} \end{aligned}$$

$$T = \frac{2\pi}{\omega} = 2\pi \sqrt{\frac{28R}{5g}}$$

Alternative Approach

$$\frac{dE}{dt} = \left(\frac{112}{5} MR^2 \right) \ddot{\theta} + 4MgR\dot{\theta} = 0$$

$$\Rightarrow \ddot{\theta} = -\frac{5g}{28R} \dot{\theta}$$

$$\omega = \sqrt{\frac{5g}{28R}}$$

$$T = \frac{2\pi}{\omega} = 2\pi \sqrt{\frac{28R}{5g}}$$

3. Alternative Approach for (3a) and (3b)

(a) For students who use the circle center as the origin:

$$h = 4R \cos \theta$$

$$\begin{aligned} PE &= mgh \\ &= -4mgR \cos \theta \end{aligned}$$

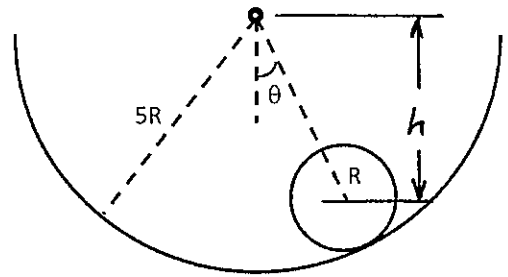

(b) For small angle, $\cos \theta \approx 1 - \frac{\theta^2}{2}$

$$PE + KE = \text{constant}$$

$$E = \frac{56}{5} mR^2 \left(\frac{\Delta \theta}{\Delta t} \right)^2 - 4mgR \cos \theta$$

$$= \frac{56}{5} mR^2 \left(\frac{\Delta \theta}{\Delta t} \right)^2 - 4mgR \left(1 - \frac{\theta^2}{2} \right)$$

$$= \frac{56}{5} mR^2 \left(\frac{\Delta \theta}{\Delta t} \right)^2 - 4mgR + 2mgR\theta^2$$

$$\Rightarrow E + 4mgR = \text{constant} = \frac{56}{5} mR^2 \left(\frac{\Delta \theta}{\Delta t} \right)^2 + 2mgR\theta^2$$

$$= \frac{1}{2} \left(\frac{112}{5} mR^2 \right) \left(\frac{\Delta \theta}{\Delta t} \right)^2 + \frac{1}{2} (4mgR) \theta^2$$

4.

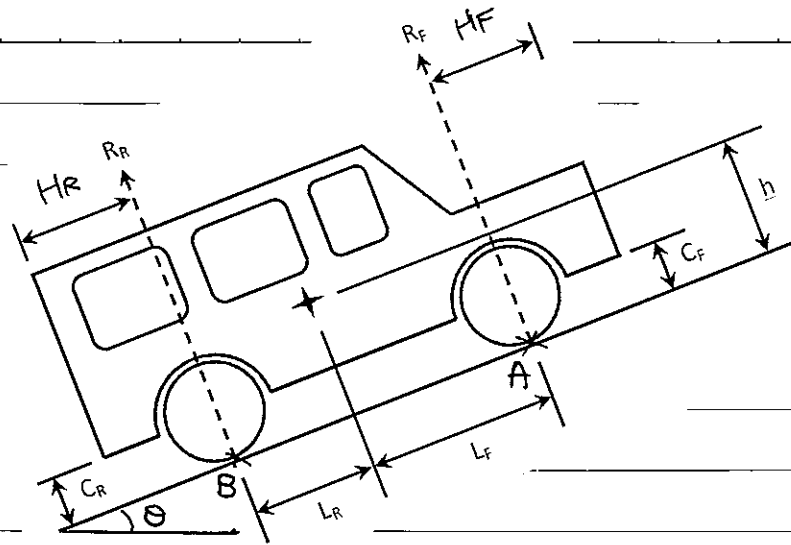

(i) Rear Wheel Drive

Moment about A :

$$mg \cos \theta L_F + mg \sin \theta h - R_R L = 0 \quad \text{--- (1)}$$

Friction :

$$f = mg \sin \theta$$

$$\text{Adhesion} \Rightarrow f_{\text{max}} = \mu R_R = mg \sin \theta$$

$$R_R = \frac{mg \sin \theta}{\mu} \quad \text{--- (2)}$$

$$\text{(1) and (2)} \Rightarrow mg \cos \theta L_F + mg \sin \theta h - \frac{mg \sin \theta}{\mu} L = 0$$

$$L_F + h \tan \theta - L \frac{\tan \theta}{\mu} = 0$$

$$\tan \theta \left(h - \frac{L}{\mu} \right) = -L_F$$

$$\tan \theta = \frac{\mu L_F}{L - \mu h}$$

(ii) Front Wheel Drive

Moment about B :

$$- mg \cos \theta L_R + mg \sin \theta h + R_F L = 0 \quad \text{--- (3)}$$

Friction :

$$f = mg \sin \theta$$

$$\text{Adhesion} \Rightarrow f_{\max} = \mu R_F = mg \sin \theta$$

$$R_F = \frac{mg \sin \theta}{\mu} \quad \text{--- (4)}$$

(3) and (4)

$$\Rightarrow - mg \cos \theta L_R + mg \sin \theta h + \frac{mg \sin \theta}{\mu} L = 0$$

$$- L_R + h \tan \theta + L \frac{\tan \theta}{\mu} = 0$$

$$\tan \theta \left(h + \frac{L}{\mu} \right) = L_R$$

$$\tan \theta = \frac{\mu L_R}{L + \mu h}$$

(iii) Four Wheel Drive

Friction : $f = mg \sin \theta$ ——— (5)

$$f_{\max} = \mu mg \cos \theta \text{ ——— (6)}$$

(5) and (6) $\Rightarrow mg \sin \theta = \mu mg \cos \theta$

$$\tan \theta = \mu$$

(iv) Overtum

Overtum $\Rightarrow R_F = 0$

(3) $\Rightarrow -mg \cos \theta L_R + mg \sin \theta h = 0$

$$\tan \theta = \frac{L_R}{h}$$

(v) Clearance

Front :

$$\tan \theta = \frac{C_F}{H_F}$$

Rear :

$$\tan \theta = \frac{C_R}{H_R}$$

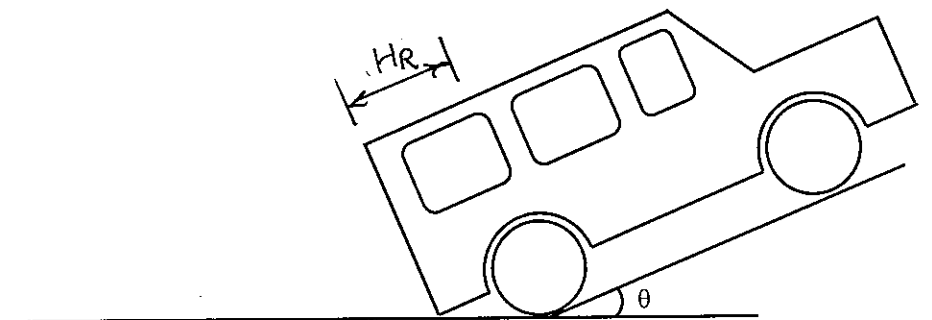
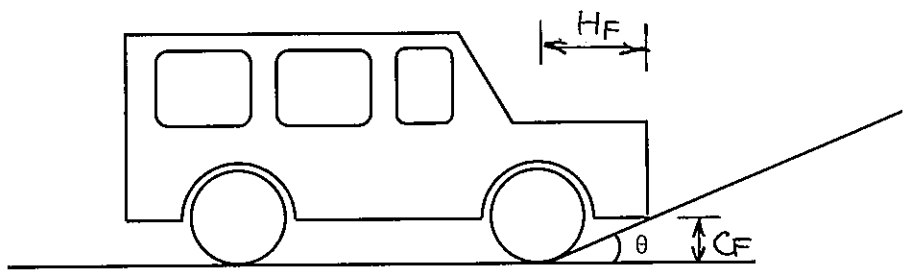

5.

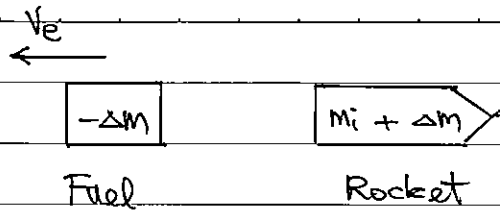

Remark: * At time $t + \Delta t$, rocket mass changes from m_i to $(m_i + \Delta m)$

* Δm is negative for decrease in rocket mass.

(a) Momentum: $-\Delta m v_e = (m_i + \Delta m) \Delta v$

$$-\Delta m v_e = m_i \cancel{\Delta v} + \Delta m \cancel{\Delta v}$$

$$\Delta v = -v_e \frac{\Delta m}{m_i}$$

(b) Acceleration $a = \frac{\Delta v}{\Delta t} = -v_e \frac{\Delta m}{m_i} \left(\frac{1}{\Delta t} \right)$

$$F = m_i a = -v_e \frac{\Delta m}{\Delta t}$$

$$\frac{\Delta m}{\Delta t} = \frac{-F}{v_e}$$

$$= \frac{-3.5 \times 10^7}{2500}$$

$$= -14000 \text{ kg/s}$$